



## 6-Pin DIP Zero-Cross Optoisolators Triac Driver Output (250 Volts Peak)

The MOC3031, MOC3032 and MOC3033 devices consist of gallium arsenide infrared emitting diodes optically coupled to a monolithic silicon detector performing the function of a Zero Voltage crossing bilateral triac driver.

They are designed for use with a triac in the interface of logic systems to equipment powered from 115 Vac lines, such as teletypewriters, CRTs, printers, motors, solenoids and consumer appliances, etc.

- Simplifies Logic Control of 115 Vac Power
- Zero Voltage Crossing
- dv/dt of 2000 V/μs Typical, 1000 V/μs Guaranteed
- **To order devices that are tested and marked per VDE 0884 requirements, the suffix "V" must be included at end of part number. VDE 0884 is a test option.**

### Recommended for 115 Vac(rms) Applications:

- Solenoid/Valve Controls
- Lighting Controls
- Static Power Switches
- AC Motor Drives
- Temperature Controls
- E.M. Contactors
- AC Motor Starters
- Solid State Relays

### MAXIMUM RATINGS (T<sub>A</sub> = 25°C unless otherwise noted)

Rating	Symbol	Value	Unit
--------	--------	-------	------

#### INFRARED LED

Reverse Voltage	V <sub>R</sub>	3	Volts
Forward Current — Continuous	I <sub>F</sub>	60	mA
Total Power Dissipation @ T <sub>A</sub> = 25°C Negligible Power in Output Driver Derate above 25°C	P <sub>D</sub>	120	mW
		1.41	mW/°C

#### OUTPUT DRIVER

Off-State Output Terminal Voltage	V <sub>DRM</sub>	250	Volts
Peak Repetitive Surge Current (PW = 100 μs, 120 pps)	I <sub>TSM</sub>	1	A
Total Power Dissipation @ T <sub>A</sub> = 25°C Derate above 25°C	P <sub>D</sub>	150	mW
		1.76	mW/°C

#### TOTAL DEVICE

Isolation Surge Voltage <sup>(1)</sup> (Peak ac Voltage, 60 Hz, 1 Second Duration)	V <sub>ISO</sub>	7500	Vac(pk)
Total Power Dissipation @ T <sub>A</sub> = 25°C Derate above 25°C	P <sub>D</sub>	250	mW
		2.94	mW/°C
Junction Temperature Range	T <sub>J</sub>	-40 to +100	°C
Ambient Operating Temperature Range	T <sub>A</sub>	-40 to +85	°C
Storage Temperature Range	T <sub>stg</sub>	-40 to +150	°C
Soldering Temperature (10 s)	T <sub>L</sub>	260	°C

1. Isolation surge voltage, V<sub>ISO</sub>, is an internal device dielectric breakdown rating. For this test, Pins 1 and 2 are common, and Pins 4, 5 and 6 are common.

**MOC3031**  
**MOC3032**  
**MOC3033**

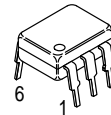

STANDARD THRU HOLE

### COUPLER SCHEMATIC

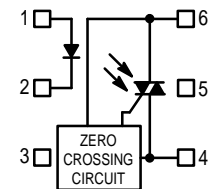

1. ANODE
2. CATHODE
3. NC
4. MAIN TERMINAL
5. SUBSTRATE  
DO NOT CONNECT
6. MAIN TERMINAL

**ELECTRICAL CHARACTERISTICS** ( $T_A = 25^\circ\text{C}$  unless otherwise noted)

Characteristic	Symbol	Min	Typ	Max	Unit
----------------	--------	-----	-----	-----	------

**INPUT LED**

Reverse Leakage Current ( $V_R = 3\text{ V}$ )	$I_R$	—	0.05	100	$\mu\text{A}$
Forward Voltage ( $I_F = 30\text{ mA}$ )	$V_F$	—	1.3	1.5	Volts

**OUTPUT DETECTOR** ( $I_F = 0$  unless otherwise noted)

Leakage with LED Off, Either Direction (Rated $V_{DRM}^{(1)}$ )	$I_{DRM1}$	—	10	100	nA
Peak On-State Voltage, Either Direction ( $I_{TM} = 100\text{ mA Peak}$ )	$V_{TM}$	—	1.8	3	Volts
Critical Rate of Rise of Off-State Voltage	dv/dt	1000	2000	—	V/ $\mu\text{s}$

**COUPLED**

LED Trigger Current, Current Required to Latch Output (Main Terminal Voltage = $3\text{ V}^{(2)}$ )	$I_{FT}$	—	—	15	mA
				10	
				5	
Holding Current, Either Direction	$I_H$	—	250	—	$\mu\text{A}$
Isolation Voltage ( $f = 60\text{ Hz}$ , $t = 1\text{ sec}$ )	$V_{ISO}$	7500	—	—	Vac(pk)

**ZERO CROSSING**

Inhibit Voltage ( $I_F = \text{Rated } I_{FT}$ , MT1–MT2 Voltage above which device will not trigger.)	$V_{IH}$	—	5	20	Volts
Leakage in Inhibited State ( $I_F = \text{Rated } I_{FT}$ , Rated $V_{DRM}$ , Off State)	$I_{DRM2}$	—	—	500	$\mu\text{A}$

1. Test voltage must be applied within dv/dt rating.
2. All devices are guaranteed to trigger at an  $I_F$  value less than or equal to max  $I_{FT}$ . Therefore, recommended operating  $I_F$  lies between max  $I_{FT}$  (15 mA for MOC3031, 10 mA for MOC3032, 5 mA for MOC3033) and absolute max  $I_F$  (60 mA).

**TYPICAL ELECTRICAL CHARACTERISTICS**

$T_A = 25^\circ\text{C}$

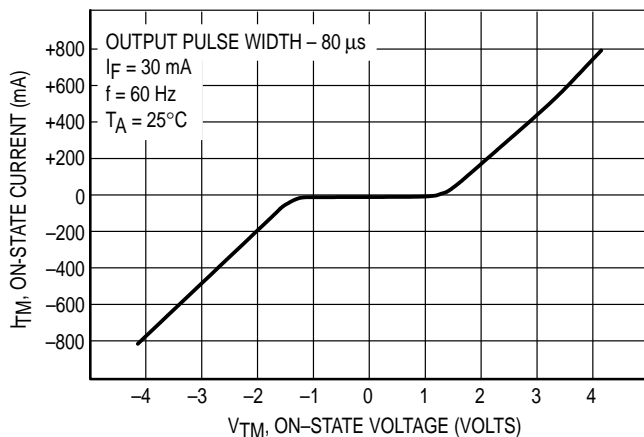

**Figure 1. On-State Characteristics**

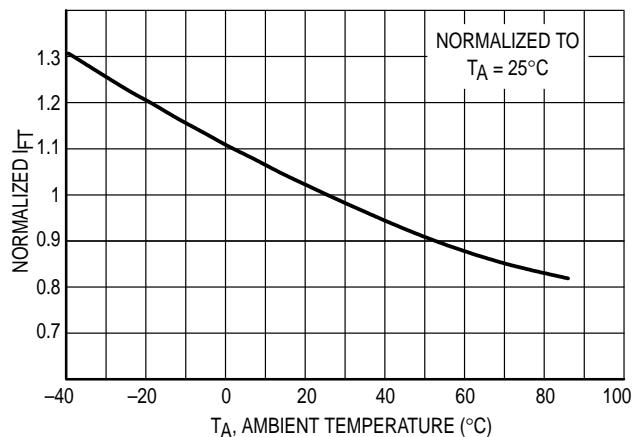

**Figure 2. Trigger Current versus Temperature**

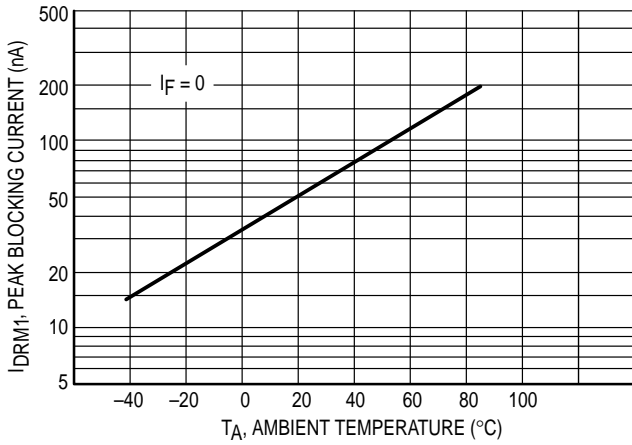

**Figure 3. IDRM1, Peak Blocking Current versus Temperature**

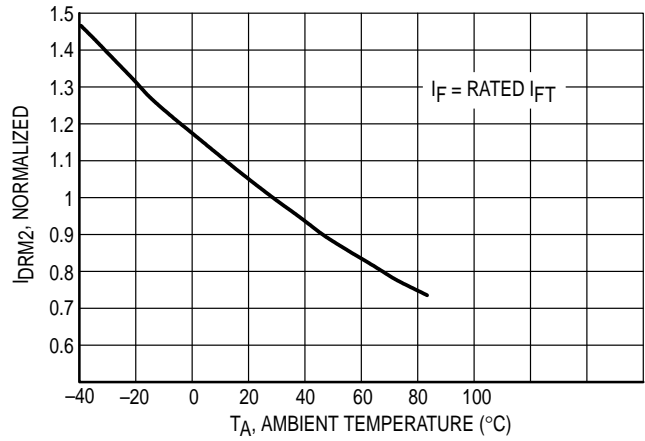

**Figure 4. IDRM2, Leakage in Inhibit State versus Temperature**

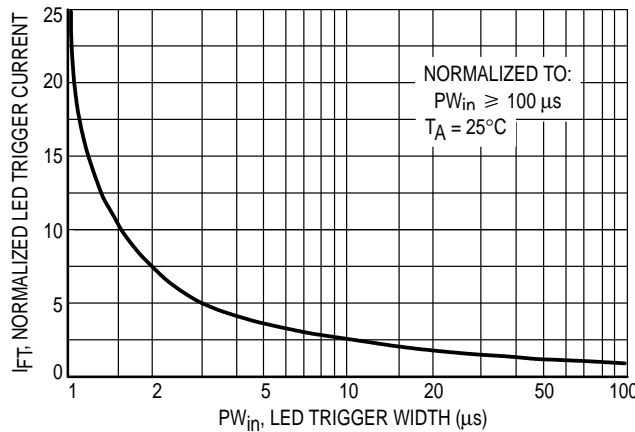

**Figure 5. LED Current Required to Trigger versus LED Pulse Width**

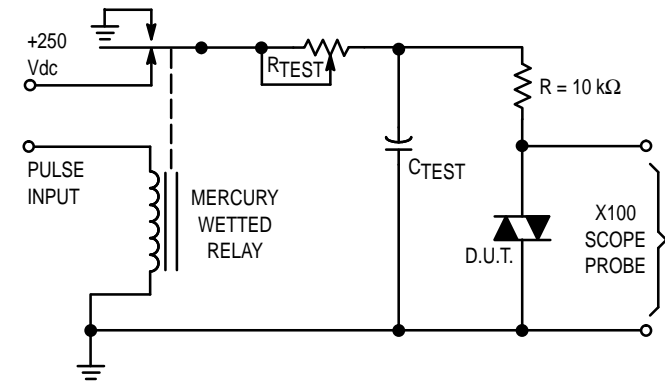

1. The mercury wetted relay provides a high speed repeated pulse to the D.U.T.
2. 100x scope probes are used, to allow high speeds and voltages.
3. The worst-case condition for static dv/dt is established by triggering the D.U.T. with a normal LED input current, then removing the current. The variable R<sub>TEST</sub> allows the dv/dt to be gradually increased until the D.U.T. continues to trigger in response to the applied voltage pulse, even after the LED current has been removed. The dv/dt is then decreased until the D.U.T. stops triggering. τ<sub>RC</sub> is measured at this point and recorded.

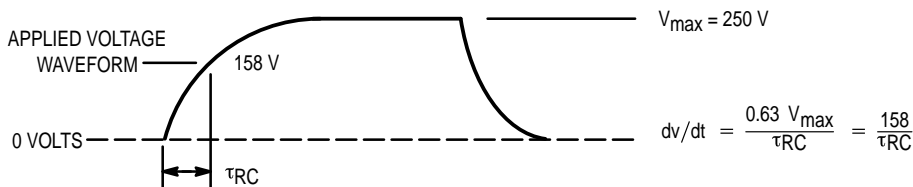

**Figure 6. Static dv/dt Test Circuit**

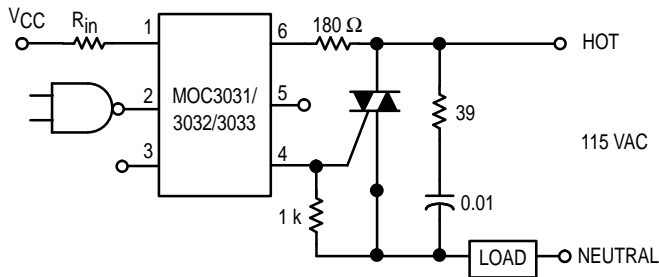

Typical circuit for use when hot line switching is required. In this circuit the "hot" side of the line is switched and the load connected to the cold or neutral side. The load may be connected to either the neutral or hot line.

$R_{in}$  is calculated so that  $I_F$  is equal to the rated  $I_{FT}$  of the part, 5 mA for the MOC3033, 10 mA for the MOC3032, or 15 mA for the MOC3031. The 39 ohm resistor and 0.01  $\mu$ F capacitor are for snubbing of the triac and may or may not be necessary depending upon the particular triac and load used.

\* For highly inductive loads (power factor < 0.5), change this value to 360 ohms.

**Figure 7. Hot-Line Switching Application Circuit**

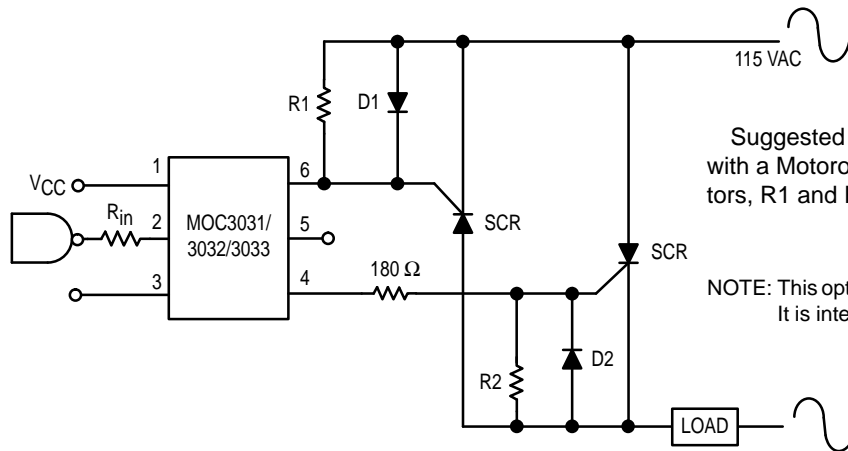

Suggested method of firing two, back-to-back SCR's, with a Motorola triac driver. Diodes can be 1N4001; resistors, R1 and R2, are optional 1 k ohm.

NOTE: This optoisolator should not be used to drive a load directly. It is intended to be a trigger device only.

**Figure 8. Inverse-Parallel SCR Driver Circuit**

**PACKAGE DIMENSIONS**

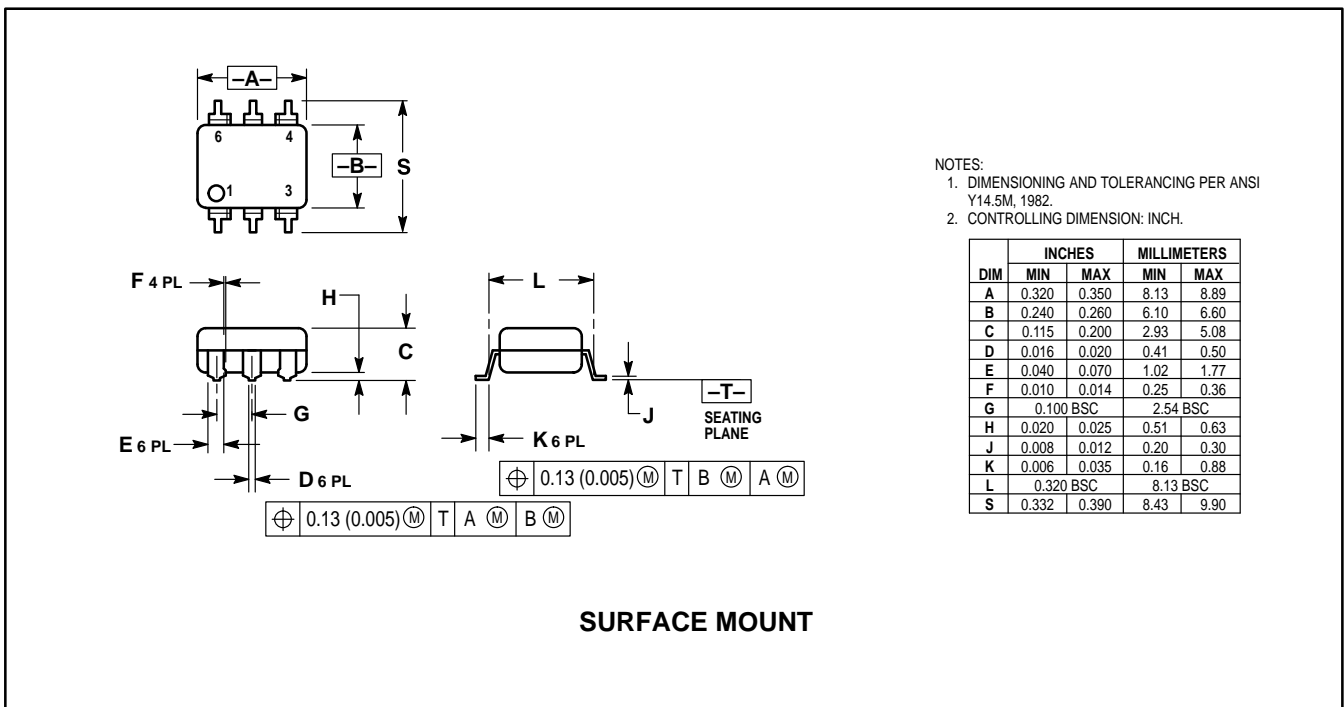
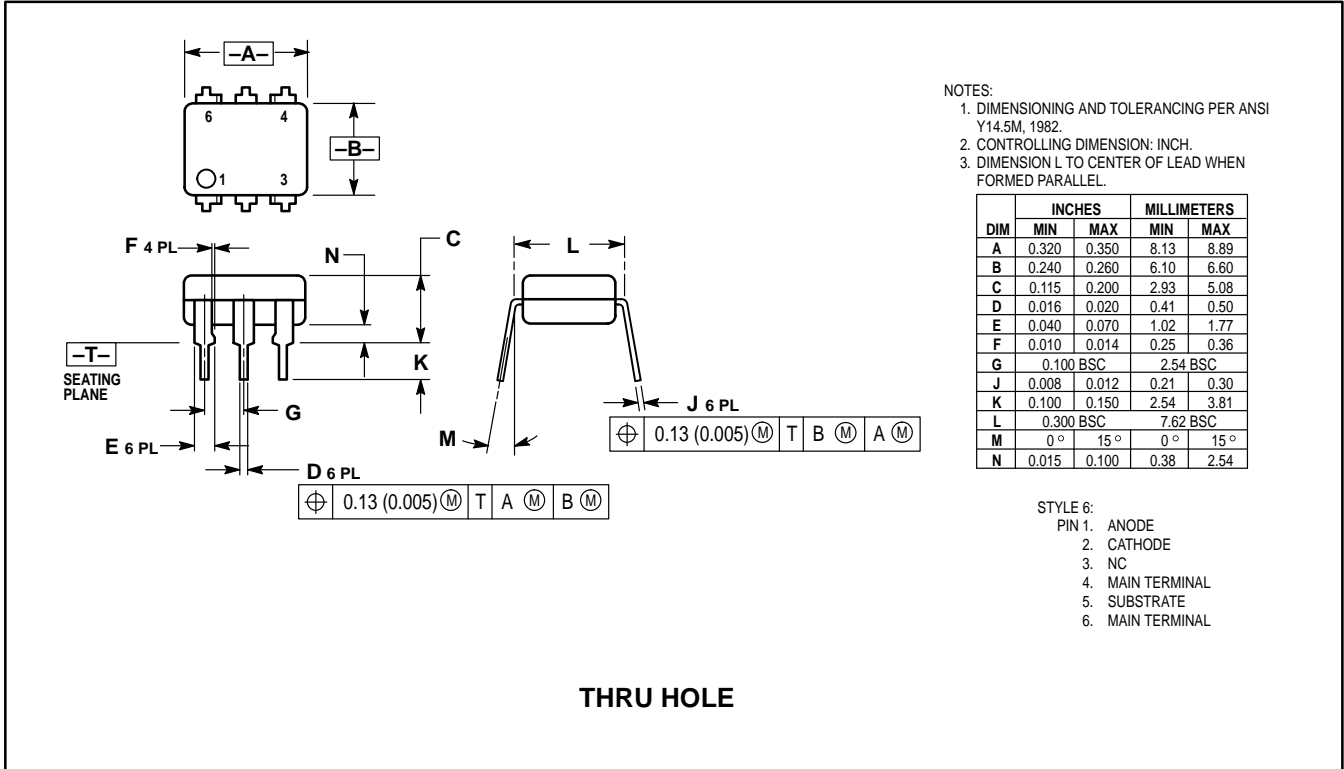

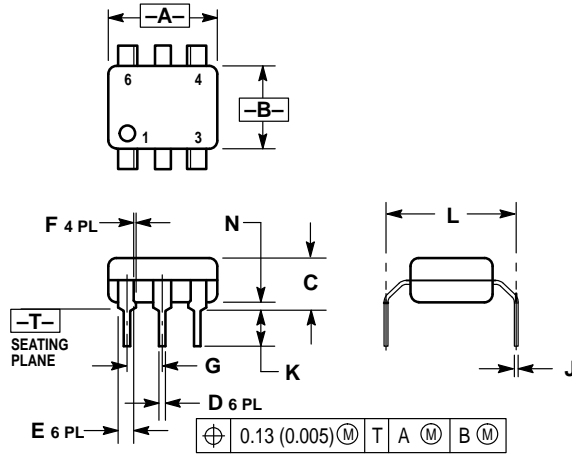

- NOTES:  
 1. DIMENSIONING AND TOLERANCING PER ANSI Y14.5M, 1982.  
 2. CONTROLLING DIMENSION: INCH.  
 3. DIMENSION L TO CENTER OF LEAD WHEN FORMED PARALLEL.

DIM	INCHES		MILLIMETERS	
	MIN	MAX	MIN	MAX
A	0.320	0.350	8.13	8.89
B	0.240	0.260	6.10	6.60
C	0.115	0.200	2.93	5.08
D	0.016	0.020	0.41	0.50
E	0.040	0.070	1.02	1.77
F	0.010	0.014	0.25	0.36
G	0.100 BSC		2.54 BSC	
J	0.008	0.012	0.21	0.30
K	0.100	0.150	2.54	3.81
L	0.400	0.425	10.16	10.80
N	0.015	0.040	0.38	1.02

**0.4" LEAD SPACING**

#### **DISCLAIMER**

FAIRCHILD SEMICONDUCTOR RESERVES THE RIGHT TO MAKE CHANGES WITHOUT FURTHER NOTICE TO ANY PRODUCTS HEREIN TO IMPROVE RELIABILITY, FUNCTION OR DESIGN. FAIRCHILD DOES NOT ASSUME ANY LIABILITY ARISING OUT OF THE APPLICATION OR USE OF ANY PRODUCT OR CIRCUIT DESCRIBED HEREIN; NEITHER DOES IT CONVEY ANY LICENSE UNDER ITS PATENT RIGHTS, NOR THE RIGHTS OF OTHERS.

#### **LIFE SUPPORT POLICY**

FAIRCHILD'S PRODUCTS ARE NOT AUTHORIZED FOR USE AS CRITICAL COMPONENTS IN LIFE SUPPORT DEVICES OR SYSTEMS WITHOUT THE EXPRESS WRITTEN APPROVAL OF THE PRESIDENT OF FAIRCHILD SEMICONDUCTOR CORPORATION. As used herein:

1. Life support devices or systems are devices or systems which, (a) are intended for surgical implant into the body, or (b) support or sustain life, and (c) whose failure to perform when properly used in accordance with instructions for use provided in the labeling, can be reasonably expected to result in a significant injury of the user.
2. A critical component in any component of a life support device or system whose failure to perform can be reasonably expected to cause the failure of the life support device or system, or to affect its safety or effectiveness.